

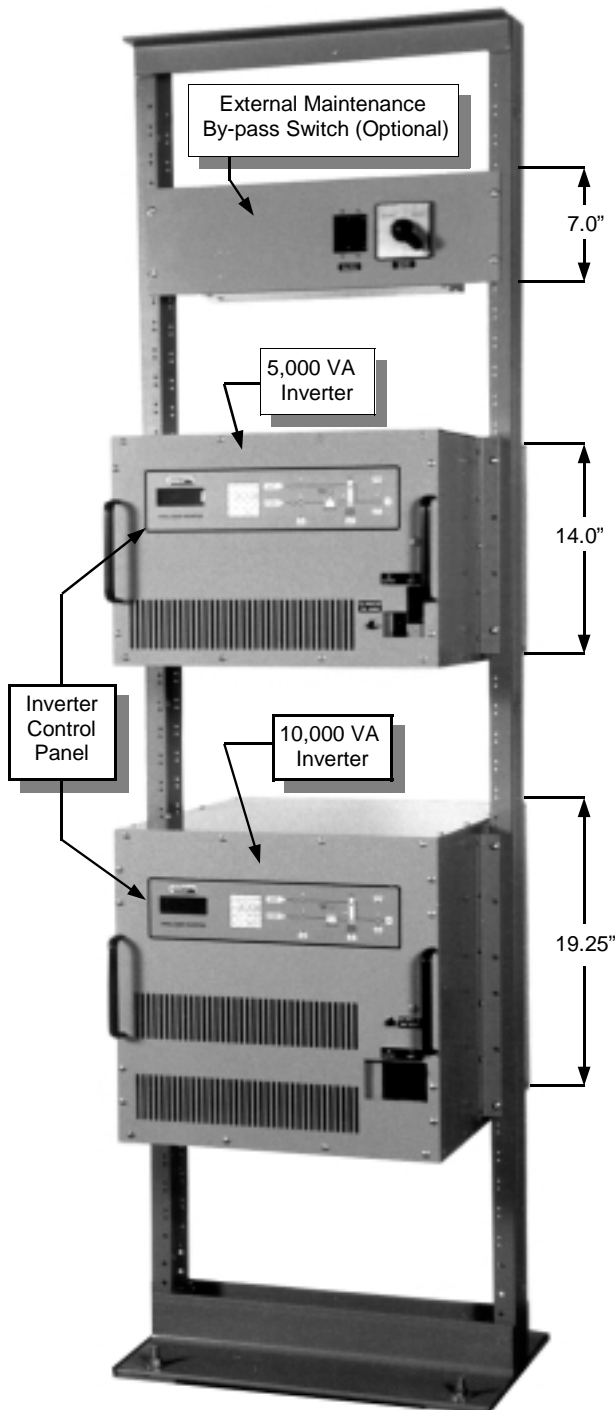

HPi Series Inverters

5 & 10 kVA 50 Hz Output

48 VDC Input



The illustration above shows relative sizes of the 5 KVA, 10 KVA Inverters and optional External By-pass Switch
This is not a typical installation



Standard Features

Microprocessor Control Circuit

- Provides comprehensive yet user friendly interface between the Inverter and the operator
- LCD Digital Meter and Alarm display
- Industrial style LED Mimic Diagram
- Control programs can be field upgraded
- RS232 Communication Port option available

Power Circuit

- High frequency switching PWM technology, using IGBTs
- Pure Sine Wave AC output
- Low audible noise
- High efficiency
- Input Output isolation
- Powers virtually any load, compatible with Nonlinear and Active Power Factor Corrected AC Loads
- DC Input Circuit Breaker
- DC Input Pre-charge Switch
- AC Output Circuit Breaker

Integral Static Bypass Switch

- Output power fully rated
- Zero Break with 2.5 mSec detection time
- User configured to operate in the On-line (Inverter preferred) or the Off-line (AC line preferred) mode
- Provides economy operation when operated in the Off-line Mode
- Provides maximum Protection when operated in the On-line Mode

Packaging

- 23" Rack Mount, compact Design
- 5 KVA Inverter occupies only 14" or 8 RU, 10 KVA Inverter occupies only 19.25" or 11 RU
- Air intake at front and exhaust at rear , top and bottom clearances are not required
- Temperature Controlled Variable Speed Fans for cooling

CSA Certified

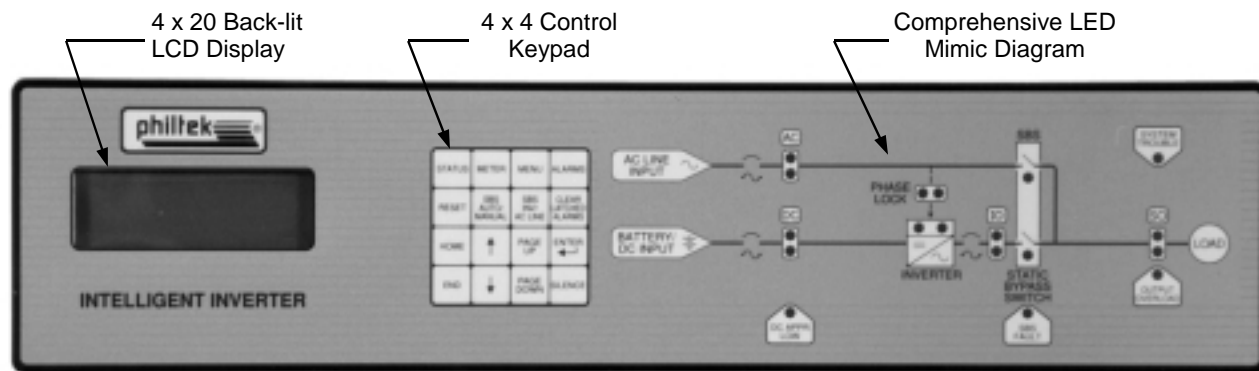

Inverter Control Panel

Inverter Specifications *(Subject to change without notice)*

DC Input

Nominal 48 V
 Range 42 to 60 V
 Current See Table
 Noise feedback < 32 dBrc

AC Output

Power See Table
 Connection 2 wires+ Gnd
 Voltage 220 Vac 1 Phase 50 Hz
 Regulation ± 1%
 Dynamic Regulation:
 100 % step load ± 4%
 Recovery < 10 mSec
 Efficiency 84 % to 87%
 Distortion (linear load) < 1.0 % THD
 Non Linear Load Capability Up to 100 %
 Active P.F. Corrected Loads Compatible
 Load Power Factor (PF) 0.8
 Frequency Tolerance ± 0.1 % free running
 Overload 120 % for 10 minutes
 Synchronization:
 Range ± 1.5 Hz
 Rate 1 Hz per Sec

Bypass AC

Connection 2 wires + Gnd
 Voltage 220V 1 Phase 50 Hz
 Current Same as output current

Static Bypass Switch

Transfer Time 2.5 mSec typical
 5 mSec maximum
 Voltage Tolerance ± 10 %
 Frequency Tolerance ± 1.5 Hz
 Overload: 120 % for 10 Minutes
 1000 % for 8 ms

Metering

Standard Output AC Volt and Amp
 with *EMD option *System Output V , A & Hz
 *Inverter Output V , A & Hz
 *Bypass AC V , A & Hz
 *DC Input V & A

Environmental

Temperature 0° C to 40° C
 Humidity 95 % RH
 Audible noise 50 dBA @ 1 meter typical
 Cooling Forced Air with temperature
 Controlled Fans

Ordering Information

Inverter Model #	Output Volt/Hz	Output VA @ 0.8 PF	Input Current @ 42 V DC	Dimensions W"x D"x H"	Weight Lbs.
HPi 5K-48-A	220/50	5,000 VA	114 Amp	23"x 22"x 14"	250 Lbs.
HPi 10K-48-A	220/50	10,000 VA	224 Amp	23"x 22"x19.25"	350 Lbs.

Option Table

Code	Option
EMD	Enhance Metering Display see *above
MBSXR	External Maintenance Bypass Switch Make before Break allows complete service with no power interruption Dimensions 23" W x 6" D x 7" H
RS232	RS 232 Communication Port allows remote control and diagnosis

For Example:
HPi 10K-48-A-MBSXR-EMD

Model No. Options

For More Information please Contact:
 In Canada **Philtek Electronics Ltd.** In USA **Philtek Power Corp.**
 Tel: (604) 270-4642 Tel: (360) 332-7252
 Fax: (604) 270-8343 Fax: (360) 332-7253
 E-mail info@philtek.com (Printed in Canada 299)